

T-Ninja Pro

Automotive Key Programming Tool

USER MANUAL



TOPDON

CONTENTS

Multilingual User Manual	4
Safety Is Always the First Priority!	4
Section 1 What's in the Box?	5
Section 2 Product Overview	6
Section 3 Using the T-Ninja Pro as a Key Programmer	14
Section 4 Using the T-Ninja Pro as a Transponder Reader and Remote Frequency Tester	21
Section 5 Using the T-Ninja Pro as a Scan Tool	25
Section 6 Update	31
Section 7 User Info	32
Section 8 Specifications	33
Section 9 Warranty	34

MULTILINGUAL USER MANUAL

For a multilingual manual in PDF form, scan the QR code below or visit www.topdon.com/products/t-ninja-pro



SAFETY IS ALWAYS THE FIRST PRIORITY!

READ ALL INSTRUCTIONS BEFORE USE



For your safety, the safety of others, and to avoid any damage to the product and your vehicle, **CAREFULLY READ AND MAKE SURE YOU FULLY UNDERSTAND ALL THE SAFETY INSTRUCTIONS AND MESSAGES ON THIS MANUAL BEFORE OPERATING.** You must also read the vehicle's service manual, and observe the stated precautions or instructions before and during any test or service procedure.



Keep yourself, your clothing and other objects away from moving or hot engine parts and avoid contact with electrical connections.



ONLY OPERATE THE VEHICLE IN A WELL-VENTILATED AREA, as the vehicle produces carbon monoxide, a toxic and poisonous gas, and particulate matter when the engine is running.



ALWAYS WEAR APPROVED SAFETY GOGGLES to prevent damage from sharp objects and caustic liquids.



DO NOT SMOKE OR HAVE ANY FLAMES NEAR THE VEHICLE when testing. The fuel and battery vapors are highly flammable.



DO NOT ATTEMPT TO INTERACT WITH THE PROUDUCT WHILE DRIVING. Any distraction may cause an accident.



TURN THE IGNITION OFF BEFORE CONNECTING OR DISCONNECTING THE PRODUCT FROM THE VEHICLE'S DATA LINK CONNECTOR (DLC) to prevent causing damage to the product or vehicle's electronic components.



DISCLAIMER: TOPDON shall not be liable for any damage or loss arising from the use of this product.

SECTION 1 WHAT'S IN THE BOX?

- T-Ninja Pro Tablet
- T-Ninja Pro VCI (Vehicle Communication Interface)
- Power Adapter
- OBD-II Extension Cable
- USB Cable (Type-A to Type-C)
- Quick User Guide
- User Manual
- Carrying Case

SECTION 2 PRODUCT OVERVIEW

2.1 T-Ninja Pro Tablet

2.1.1 Feature Description

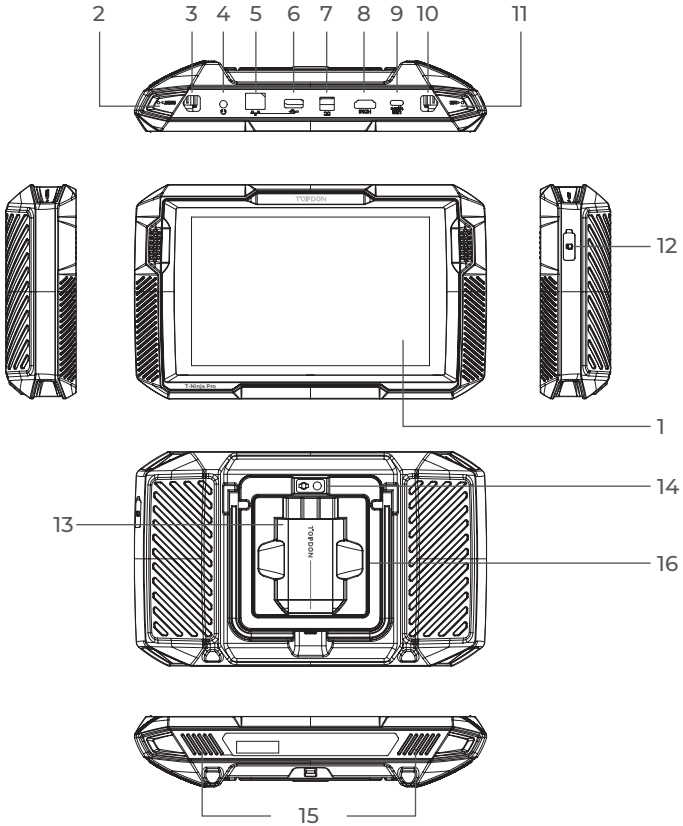

Figure 2-1

- 1. Eight-Inch Touch Screen**
- 2. Reset Button**

Insert a pin (not included) into the pinhole and press and hold for 10 seconds to force restart the tablet.
- 3. Power Button**

Long press the button to turn on the tablet. Long press again to display the Power off / Restart / Screenshot toolbar, then tap the desired option.
Short press the button to wake up / lock the screen.
- 4. 3.5 mm Audio Port**
- 5. RJ45 Port**
- 6. USB Type-A Port**

Connects the T-Ninja Pro tablet and the VCI / T-Darts using the supplied USB cable.
- 7. DC Power Supply Input Port (12V, 2A)**

Charges the T-Ninja Pro tablet using the supplied power adapter.
- 8. HDMI Port**
- 9. USB Type-C Port**

For data transfer and charging (5V, 2A)
- 10. Screenshot Button**

Press and hold for 2 seconds to take a screenshot.
- 11. Mic**
- 12. TF Card Expansion Slot**

Supports hot swap and up to 128 GB storage expansion.
- 13. VCI Slot**
- 14. Camera Lens**
- 15. Audio Speaker**
- 16. Collapsible Stand**

2.1.2 Home Screen

Open the T-Ninja Pro app, and the home screen will display.

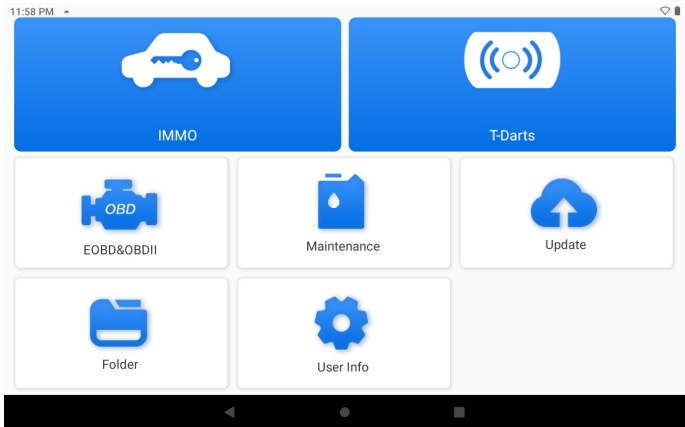

Figure 2-2

1. Function Icons



IMMO
(Immobilizer)

Allows you to perform IMMO related functions such as **Number of Keys, Read Pin Code, Remote Control Learning, Add Key, Erase Key** and **All Key Lost**.



T-Darts

Configures the T-Ninja Pro to operate as a transponder reader and remote frequency tester.



EOBD & OBD-II

Configures the T-Ninja Pro to operate as a scan tool.



Maintenance

Provides 8 maintenance services.



Update

Allows you to update the vehicle-specific IMMO, T-Darts and Diagnostics software if a new version is available.



Folder

Opens the management system for the saved data files.



User Info

Provides access to **My Profile, VCI Management, Firmware Update, Vehicle Management, Customer Feedback, Shop Info, and Settings.**

2. Navigation Bar



Selecting this icon returns you to the previous screen.



Selecting this icon returns you to the home screen of Android System.



Selecting this icon displays a list of the opened apps. You can swipe left or right to view the full list, tap to open the app, or swipe up to remove the app.

2.2 T-Ninja Pro VCI

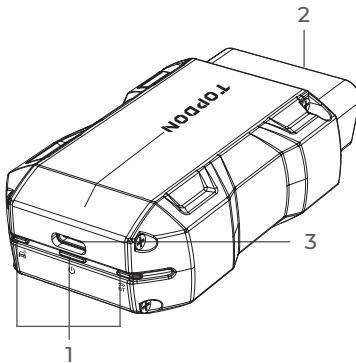

Figure 2-3

1. Indicators



Bluetooth
Connection Indicator

Solid Blue: Bluetooth connected



Power
Indicator

Solid Red: power on



Communication
Indicator

Flashing Green: communicating with
the vehicle

2. OBD-II 16 Pin Connector

Connects the VCI to vehicle's DLC.

3. USB Type-C Port

Connects the VCI to the T-Ninja Pro tablet using the supplied USB cable.

2.3 T-Darts Transponder & Remote Tester Tool (Optional Accessory)

2.3.1 Feature Description

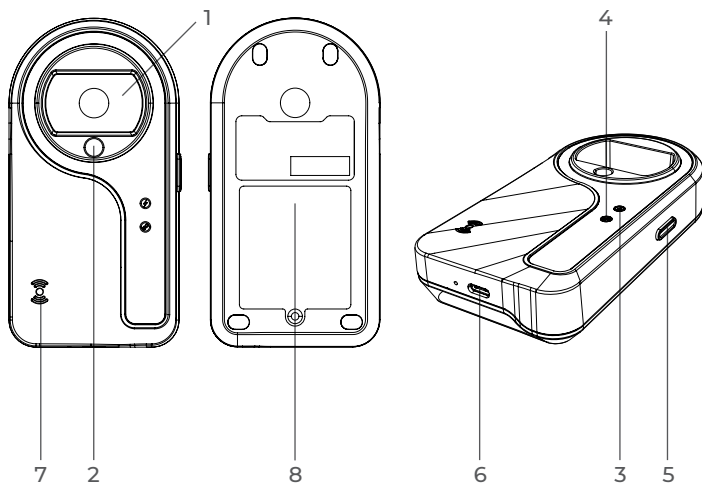

Figure 2-4

- 1. Vehicle Key Slot**
- 2. Transponder Slot**
- 3. Power Indicator**
Solid blue: power on
- 4. Bluetooth Connection Indicator**
Solid green: Bluetooth connected
- 5. Power Button**
Long press the button to turn on the T-Darts.
- 6. USB Type-C Port**
Connects the T-Darts to the T-Ninja Pro tablet using the supplied USB cable.
- 7. Frequency Induction Antenna**
Detects remote frequency at a standard distance of 1-10cm.
- 8. Battery Compartment**
Accepts 4 AAA batteries

2.3.2 Power Source

The T-Darts can be powered by 4 AAA batteries or an external USB power source.

When the T-Darts is connected to the T-Ninja Pro tablet via a USB cable, it is powered by the tablet through the USB connection.

Alternatively, you can install four AAA batteries to power the T-Darts (see Figure 2-5).

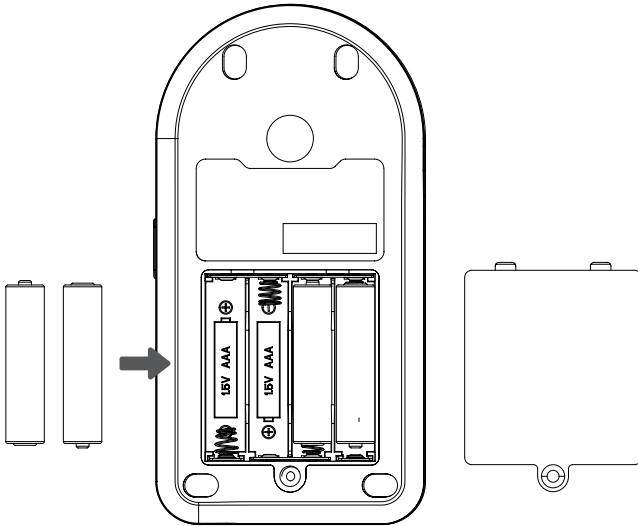

Figure 2-5

SECTION 3 USING THE T-NINJA PRO AS A KEY PROGRAMMER

3.1 Getting Started

3.1.1 Register & log in

Open the T-Ninja Pro app and log in to your TOPDON account. (If you do not have an account, please register with your email.)

3.1.2 Plug the VCI into the vehicle's DLC

Note:

Make sure the ignition is OFF before plugging in the VCI.

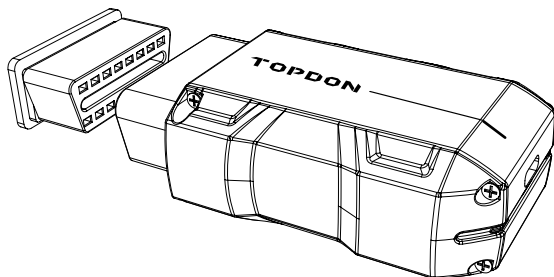

Figure 3-1

DLC for most vehicles is located in one of the positions marked in Figure 3-2. If you encounter a problem in locating DLC, please refer to the vehicle's service manual.

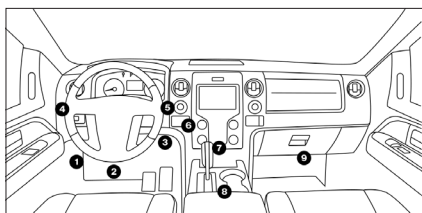

Figure 3-2

3.1.3 Turn the ignition to the "ON" position (see Figure 3-3)

If your vehicle is equipped with a keyless start system and the ignition switch is an "Engine Start Stop" button (see Figure 3-4), press the "Engine Start Stop" button until the car is in "ON" mode. Do not apply the brake while pressing the "Engine Start Stop" button, or you will start the engine instead of putting it in the "ON" position.

The method of ignition varies by vehicle model. Refer to the vehicle's service manual for details.



Figure 3-3

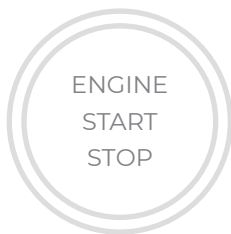



Figure 3-4

3.1.4 Bind the VCI

- ① Go to **User Info > VCI Management**. Tap the  icon at the top right corner of the screen, and the device will ask you to connect the Bluetooth first.
- ② Connect the Bluetooth as prompted. Then the serial number and activation code will be automatically obtained.

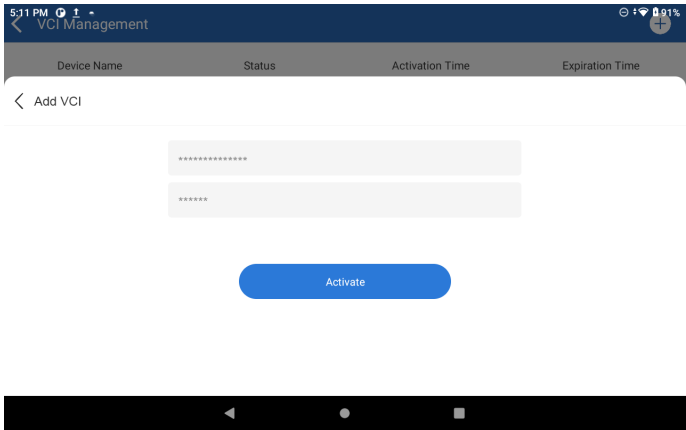

Figure 3-5

③ Then, tap **Activate**.

3.1.5 Connect the VCI to the T-Ninja Pro tablet

The VCI can be connected to the T-Ninja Pro tablet either via wireless (Bluetooth) or wired connection (USB cable).

Wireless Connection

Tap **IMMO** from the home screen, and tap the **VCI** icon at the upper right of the screen to establish Bluetooth connection with the VCI. After the VCI is successfully connected, the icon changes to **VCI**.

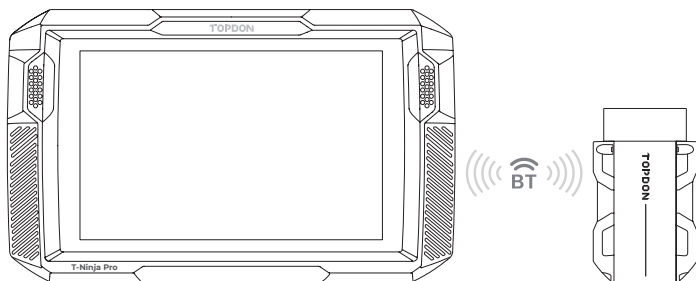

Figure 3-6

Note:

Once the VCI has been successfully connected to your T-Ninja Pro tablet via Bluetooth, the connection will be automatically resumed next time when you open the T-Ninja Pro app. If not connected, manually tap **VCI** to reconnect.

Wired Connection

Use the supplied USB cable to connect the VCI to the T-Ninja Pro tablet (see Figure 3-7). After the VCI is properly connected to the tablet, the **VCI** icon changes to **VCI^o**.

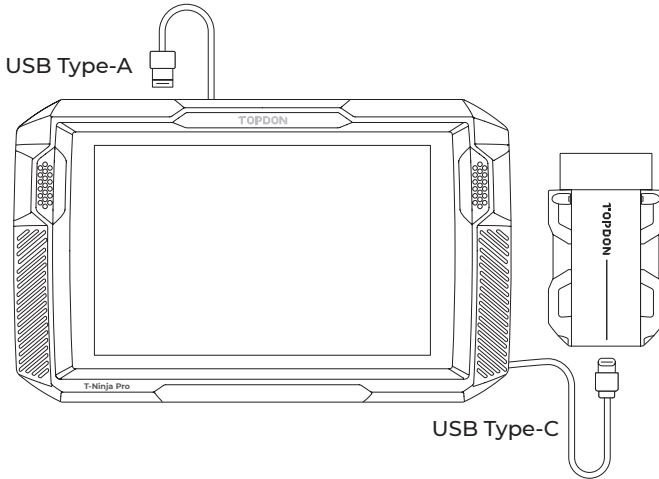

Figure 3-7

Note:

1. Once wired connection is applied, Bluetooth will be disconnected automatically.
2. For stable communication, wired connection is recommended.

3.2 IMMO

1. Tap **IMMO** from the home screen. The following screen will display.



Figure 3-8

- ① Search Bar
Enter vehicle make to search.
- ② Home
Tap to return to the home screen.
- ③ VIN / Make
Tap to toggle between the two identification screens: VIN and Make.
- ④ All / Asia / Europe / America / China / Australia
Select from this menu to filter the vehicle makes made in certain countries.
- ⑤ T-Darts Icon
Indicates the connectivity status of the T-Darts.
- ⑥ VCI Icon
Indicates the connectivity status of the VCI.
- ⑦ Vehicle Battery Voltage Icon
Display the real-time voltage of your vehicle battery.

Note:

Before performing the IMMO functions, please check for a normal battery voltage (12V ± 20%). DO NOT PERFORM THE FUNCTIONS IF THE VOLTAGE IS TOO LOW / HIGH. A low battery voltage may cause communication error, while a high voltage may cause damage to your vehicle, the tool, or endanger the user.

- ⑧ **Manufacturer (Vehicle Make) Options**
Select an option by your vehicle make to enter the IMMO functions.

2. Identify the vehicle

To access the IMMO functions, you need to identify your vehicle first. You can either identify the vehicle via VIN or Make.

Identifying via VIN

VIN allows you to identify the vehicle via Auto VIN or Enter VIN.

- Auto VIN - The T-Ninja Pro tablet automatically reads and decodes the Vehicle Identification Number (VIN).
- Enter VIN - manually enter or scan the vehicle VIN to identify the vehicle.

Identifying via Make

Select the desired manufacturer option from the Make screen. Then, select Automatic Selection, Manual Selection, or System Selection to identify the vehicle.

Note:

Identification options and procedures may vary by vehicle make.

- Automatic Selection - The T-Ninja Pro tablet automatically communicates with the vehicle to complete the vehicle identification process.

Note:

Automatic Selection is only available for certain vehicle makes (e.g. Nissan, Infiniti, Chrysler, Dodge and Jeep, etc.).

- Manual Selection - manually select the vehicle information to access the IMMO system.
- System Selection - directly select the type of the vehicle IMMO system.

3. A function menu will display after the vehicle is identified. Select a function to continue. Follow the on-screen instructions to perform the procedures.

Note:

Available functions may vary by vehicle make, model and year.

Typical function options may include:

- **Number of Keys**
- **Read Pin Code**
- **Remote Control Learning**
- **Add Key**
- **Erase Key**
- **All Key Lost**
- **Clear DTCs**

SECTION 4 USING THE T-NINJA PRO AS A TRANSPONDER READER AND REMOTE FREQUENCY TESTER

Note:

To access the T-Darts function, the T-Darts accessory (sold separately) is required.

4.1 Getting Started

1. Long press the power button to turn the T-Darts on

Note:

T-Darts will automatically turn off if no operation is performed within 5 minutes.

2. Long press the power button to turn the tablet on

3. Connect the T-Darts to the T-Ninja Pro tablet

The T-Darts can be connected to the T-Ninja Pro tablet either via wireless (Bluetooth) or wired connection (USB cable).

Wireless Connection

Tap **T-Darts** from the home screen, and tap the **T-Darts** ^x icon at the upper right of the screen to establish Bluetooth connection with the T-Darts. After the T-Darts is successfully connected, the icon changes to **T-Darts** ⁺, while the Bluetooth connection indicator on the T-Darts illuminates green.

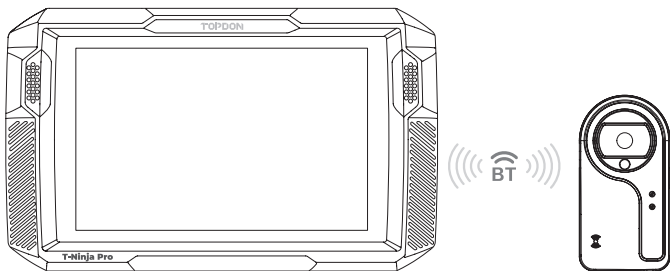

Figure 4-1

Wired Connection

Use the supplied USB cable to connect the T-Darts to the T-Ninja Pro tablet (see Figure 4-2). After the T-Darts is properly connected to the tablet, the **T-Darts** ^x icon changes to **T-Darts** ⁺.

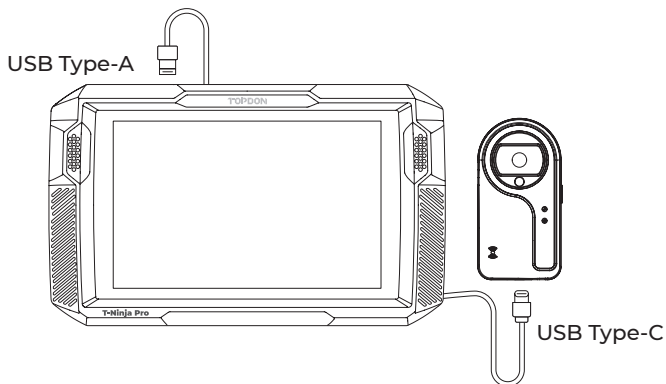

Figure 4-2

Note:

For stable communication, wired connection is recommended.

4.2 T-Darts

4.2.1 Transponder Recognition

To view the transponder information:

1. Tap **T-Darts > Transponder Recognition > Key Read**.
2. Place the test key into the key slot or place the test transponder into the transponder slot (see Figure 4-3).



Figure 4-3

3. Detailed transponder information will be displayed on the screen.
4. To read transponder information of a second key, simply remove the previous key, place the key that you wish to read into the slot, and tap **Read**. The detailed information will be displayed on the screen.

4.2.2 Frequency Detection

To view the key frequency information:

1. Tap **T-Darts > Frequency Detection > Remote Detection**.
2. Place the test key 1-10cm away from the frequency induction antenna and press any button of the test key.



Figure 4-4

3. Remote frequency information will be displayed.

Note:

1. Every time you press the key button, the power indicator on the T-Darts unit will flash blue, indicating the frequency testing process.
2. The testable frequency range is as follows: 300~320MHz, 430~434MHz, 868MHz, 902~915MHz.

SECTION 5 USING THE T-NINJA PRO AS A SCAN TOOL

Note:

Please ensure that the VCI is properly plugged into the vehicle's DLC and connected to the T-Ninja Pro tablet via Bluetooth or the provided USB cable. For detailed operation, please refer to **3.1 Getting Started**.

5.1 EOBD & OBD-II

The EOBD & OBD-II function allows you to perform emission-related diagnostics for your vehicle.

To perform EOBD & OBD-II Diagnostics:

1. Tap **EOBD & OBD-II** from the home screen.

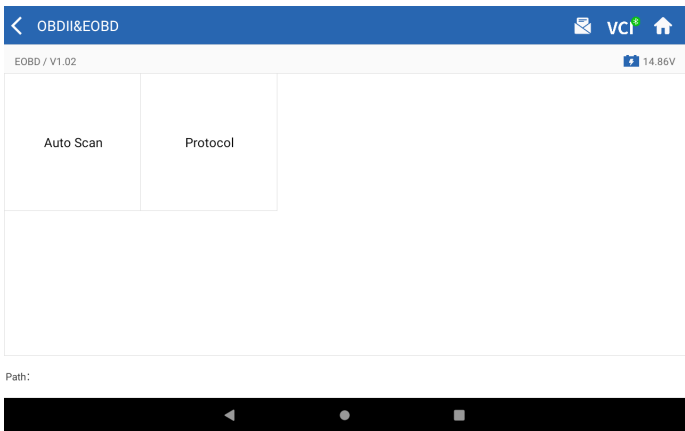

Figure 5-1

2. Select your communication method: **Auto Scan or Protocol**.

Auto Scan - The T-Ninja Pro will automatically communicate with the vehicle and identify which protocol the vehicle is using.

Protocol - allows you to manually select the communication protocol. After the communication protocol is confirmed, a vehicle status screen displays showing the protocol and other status info of your vehicle.

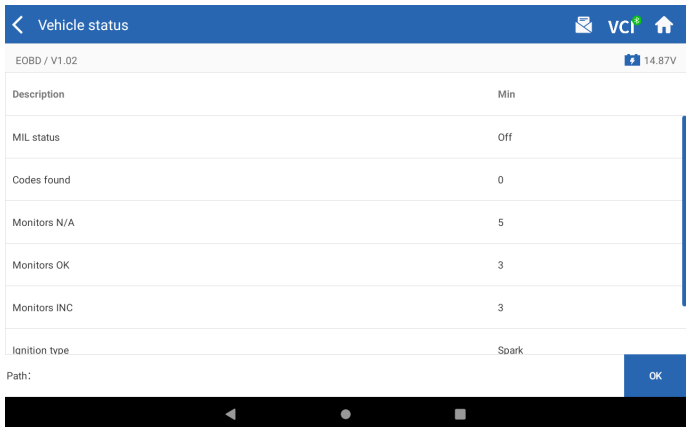

Figure 5-2

3. Tap **OK** to enter the function menu.

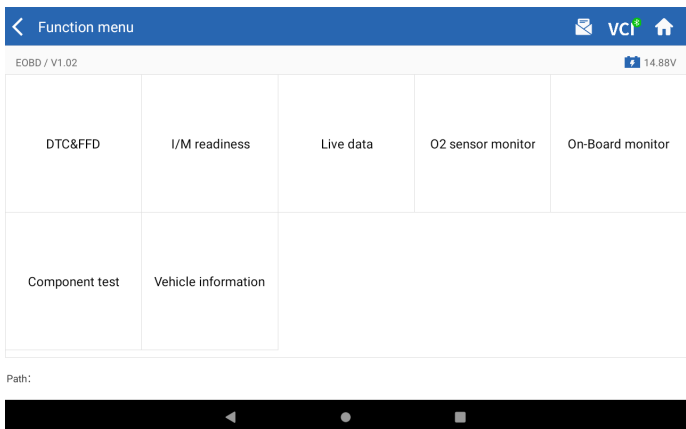

Figure 5-3

4. Select a function to continue.

Note:

Depending on the vehicle make, some functions may not be available.

Typical function options may include:

- **DTC & Freeze Frame Data**
- **I/M Readiness**
- **Live Data**
- **O2 Sensor Monitoring**
- **On-Board Monitoring**
- **Component Testing**
- **Vehicle Information**

DTC & FFD (Freeze Frame Data)

This function helps retrieve and clear DTCs stored in the vehicle's Electronic Control Unit (ECU) and displays FFD of the emission-related systems.

1. Read DTCs

This function displays the DTCs retrieved from the emission-related systems.

2. Clear DTCs

This function allows you to clear the DTCs retrieved from the emission-related systems.

3. FFD

This function takes a snapshot of the data and operating conditions when an emission-related fault occurs.

Note:

1. The procedure of clearing DTCs should be performed after the required repair has been carried out. Once confirmed, DTCs and FFD stored in the ECU will be cleared.
2. DO NOT START UP THE ENGINE WHILE CLEARING DTCs.

I/M (Inspection and Maintenance) Readiness

This function checks whether or not the various emission-related systems on the vehicle are operating properly, and are ready for I/M testing.

It can also be used to check the monitor running status and to confirm

if the repair of a car fault has been performed correctly.

Live Data

This function displays the real-time live data and parameters from the vehicle's ECU.

O2 Sensor Monitor

This function displays O2 sensor monitor test results of the most recently completed tests from the vehicle's ECU.

On-Board Monitor

This function displays the test results for emission-related powertrain components and systems that are not continuously monitored.

Component Test

This function helps send control commands to the vehicle's ECU as a way to test and operate the system parts and components.

Vehicle Information

This function displays a list of information (provided by the vehicle manufacturer) from the vehicle's ECU.

The information may include:

- Vehicle Identification Number (VIN)
- Calibration ID (CID)
- Calibration Verification Number (CVN)

5.2 Maintenance

This function provides you with 8 maintenance services including Oil Reset, Throttle Adaptation, Electronic Parking Brake (EPB) Reset, Steering Angle Reset, Diesel Particulate Filter (DPF) Regeneration, Anti-lock Braking System (ABS) Bleeding, Battery Management System (BMS) Reset and Airbag Reset.

5.2.1 Services Overview

Oil Reset

This function allows you to reset the oil service lamp for the engine oil life system, which calculates an optimal oil life change interval depending on the vehicle driving conditions and weather events. Oil reset is required every time the engine oil is changed.

EPB Reset

This function helps you replace and reset the brake pads.

It needs to be performed in the following cases:

- After the brake pads and brake pad wear sensor are replaced;
- When the brake pad warning light is on;
- After a short circuit in the brake pad sensor is fixed;
- After the servo motor is replaced.

Steering Angle Reset

If the steering angle sensor is replaced, or the steering angle is inaccurate or not centered, the steering angle reset function needs to be performed to find the relative zero position. With this position as a reference, the ECU can then calculate the exact angle for left and right steering.

BMS Reset

After the car battery is replaced, the car battery control unit needs to be reset. This will clear fault information (such as low battery level) so that the control unit can match the relevant information of the newly replaced battery.

ABS Bleeding

When the brake system is opened to replace components such as brake pump, master cylinder, brake lines or brake fluid, air gets inside, which can lead to a soft brake pedal. ABS Bleeding is required to restore the firmness of the brake pedal.

Throttle Adaptation

If the ECU is disconnected accidentally, or if the throttle is replaced or cleaned, then the throttle actuators need to be initialized via the Throttle Adaptation function. This resets the ECU's data to its initial state so that the throttle can accurately regulate the air intake.

DPF Regeneration

This function is mainly used for the regeneration of diesel particulate filters. To keep the filters performing well it removes particles by means of combustion and oxidation.

Airbag Reset

This function allows you to reset the airbag data to turn off the airbag light, so that the airbag control module can run normally.

It needs to be performed in the following cases:

- When the airbag deploys;
- When the diagnostic tool reads "Crash data stored";
- When the airbag light is on;
- When relevant DTCs cannot be cleared.

5.2.2 Steps

To perform a service reset:

1. Tap **Maintenance** from the home screen. A function menu will display.

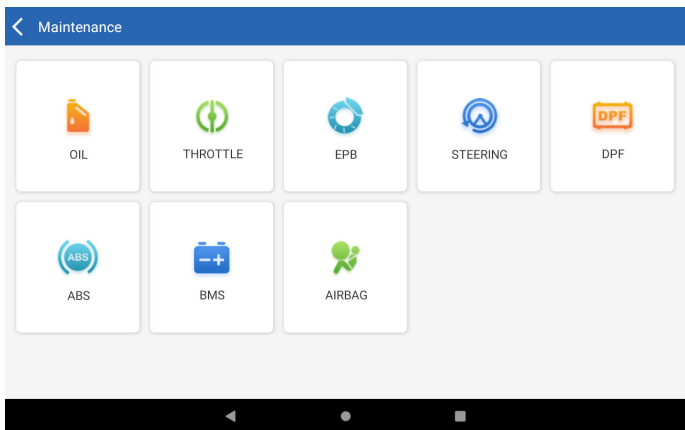

Figure 5-4

2. Select a function that you want to perform. A list of vehicle makes will display.
3. Vehicle identification is required before you can access the function. When it completes, the function menu displays.
4. Follow the on-screen instructions to perform the service reset.

SECTION 6 UPDATE

To update the vehicle-specific IMMO / T-Darts / Diagnostics software:

1. Tap **Update** from the home screen. The following screen will display.

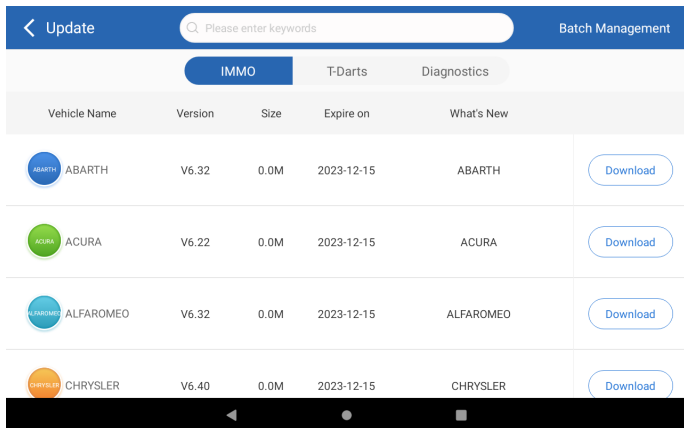

Figure 6-1

2. Tap **IMMO / T-Darts / Diagnostics** to look for a desired vehicle software, or search the software by a keyword.

3. Tap **Download / Update** to install the software as you like.

SECTION 7 USER INFO

The User Info function provides access to **My Profile**, **VCI Management**, **Firmware Update**, **Vehicle Management**, **Customer Feedback**, **Shop Info**, and **Settings**.

7.1 My Profile

You can tap the profile photo in the User Info screen to enter the My Profile page. With this function, you can change your profile photo / nickname, view your TOPDON ID, change the password, and delete your TOPDON account.

7.2 VCI Management

Allows you to bind the VCI to the T-Ninja Pro tablet.

7.3 Firmware Update

Allows you to update the VCI / T-Darts firmware if a new version is available.

7.4 Vehicle Management

Allows you to delete vehicle-specific IMMO, T-Darts or Diagnostics software.

7.5 Customer Feedback

Allows you to write a feedback on the product to the TOPDON after-sales team.

7.6 Shop Info

Allows you to save the information of the repair shop.

7.7 Settings

The Settings function allows you to set languages / unit, clear cache, view the version information of the T-Ninja Pro app, update the T-Ninja Pro app and view Terms of Service and Privacy Policy.

SECTION 8 SPECIFICATIONS

Operating System	Android 11.0
RAM	2G
Storage Capacity	32G
Display Screen	8-inch screen, 1280 x 800
Connectivity	Bluetooth 5.0/SPP USB Wi-Fi
Camera	5 megapixels
Audio I/O	Microphone / loudspeaker
Sensor	Gravity sensor
Battery Capacity	10,000 mAh
Input Voltage	12V DC
Ports	USB Type-A USB Type-C RJ45 HDIM DC charging port
Network Connection	Wi-Fi RJ45
Dimensions (L x W x H)	10.04 × 6.10 × 1.97 in. (255 x 155 x 50 mm)
Working Temperature	32 °F to 122 °F (0°C to 50°C)
Storage Temperature	-4 °F to 140 °F (-20°C to 60°C)

SECTION 9 WARRANTY

TOPDON One Year Limited Warranty

TOPDON warrants to its original purchaser that the company's products will be free from defects in material and workmanship for 12 months from the date of purchase (Warranty Period).

For the defects reported during the Warranty Period, TOPDON will either repair or replace the defective part or product according to its technical support analysis and confirmation.

TOPDON shall not be liable for any incidental or consequential damages arising from the device's use, misuse, or mounting.

If there is any conflict between the TOPDON warranty policy and local laws, the local laws shall prevail.

This limited warranty is void under the following conditions:

- Misused, disassembled, altered or repaired by unauthorized stores or technicians.
- Careless handling and/or improper operation.

Notice:

All information in this manual is based on the latest information available at the time of publication and no warranty can be made for its accuracy or completeness. TOPDON reserves the right to make changes at any time without notice.

SECTION 10 FCC

Any changes or modifications not expressly approved by the party responsible for compliance could void the user's authority to operate the equipment.

This device complies with Part 15 of the FCC Rules. Operation is subject to the following two conditions:

- (1) this device may not cause harmful interference, and
- (2) this device must accept any interference received, including interference that may cause undesired operation.

Note: This equipment has been tested and found to comply with the limits for a Class B digital device, pursuant to Part 15 of the FCC Rules. These limits are designed to provide reasonable protection against harmful interference in a residential installation. This equipment generates, uses, and can radiate radio frequency energy, and if not installed and used in accordance with the instructions, may cause harmful interference to radio communications. However, there is no guarantee that interference will not occur in a particular installation. If this equipment does cause harmful interference to radio or television reception, which can be determined by turning the equipment off and on, the user is encouraged to try to correct the interference by one or more of the following measures:

- Reorient or relocate the receiving antenna.
- Increase the separation between the equipment and receiver.
- Connect the equipment into an outlet on a circuit different from that to which the receiver is connected.
- Consult the dealer or an experienced radio/TV technician for help.

www.rptoolsitaliastore.com
info@rptoolsitaliastore.com facebook:
www.facebook.com/rptoolsitalia.it
Via Predda Niedda str 11, n 14 07100 Sassari
Contatti e info:
+ 39 3491149384
+ 39 3514120848

	TEL	86-755-21612590 1-833-629-4832 (NORTH AMERICA)
	EMAIL	SUPPORT@TOPDON.COM
	WEBSITE	WWW.TOPDON.COM
	FACEBOOK	@TOPDONOFFICIAL
	TWITTER	@TOPDONOFFICIAL



RoHS

